

FIRE & Water<sup>®</sup>

LIGHTING

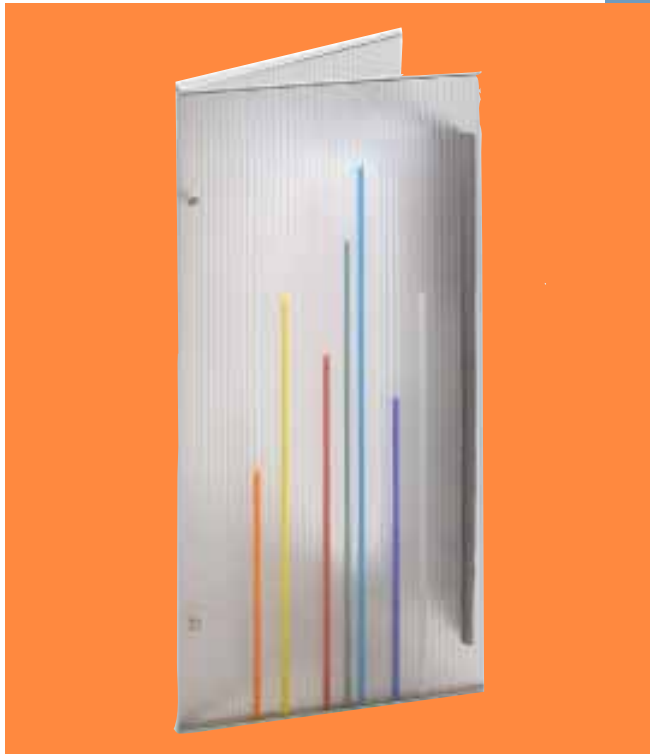

*Environmentally conscious... and handsome, too*  
Catalog and Custom Designs by David Bergman

## SUSTAINABLE DESIGN PRACTICES AT FIRE & WATER

Environmentally sustainable product design and sustainable business practices are fundamental to Fire & Water. While it is difficult for a small company to undertake far-reaching research and development, we endeavor to constantly improve the environmental aspects of our existing products; to design new, more sustainable products; to use cutting edge energy saving technology; and to utilize wherever possible sustainable practices within our office and shop.

**Materials.** Most of our product lines (with the exception of two early legacy lines) are designed around sustainable and/or recycled materials. A favorite of ours, incorporated in many of our designs, is a biocomposite made of recycled newsprint and soy flour. Several of our product series make extensive use of custom recycled glass, another uses recycled plastic and yet another has shades made of sustainably harvested wood veneer. Much of the metals utilized are scrap or cutoffs from salvage shops and other metal shops (cleaned and looking new, of course).

**Finishes.** Almost all of our finishes are now water base and/or low VOC. We admit there are a few instances where, due to the limitations of being a small shop, we have to resort to standard (nasty) finishes, but we are close to eliminating the last of them.

**Recyclability.** Our products are designed to enable simple dismantling at the ends of their lives. The materials are mostly non-complex, meaning they can easily be separated and sorted for reuse. Most methods of attachment between materials are mechanical, which further enables future dismantling.

**Energy use.** All of our newer lighting designs can utilize energy efficient light sources. Our compact fluorescent lines have all been modified to utilize the new GU24 dedicated CFL sockets, making them eligible for Energy Star listing (we are working on that). And our newest line, cycLED, uses color changing LEDs.

**Packaging.** Though it is crucial that delicate items such as light fixtures be well protected during shipment, we try to minimize the impact of our packaging. We use a combination of reclaimed, recycled and, at times, virgin packing materials. (We experimented with using corn starch packing peanuts but had a rodent problem!) Please try to reuse or recycle the packaging materials when you receive our products. Most local shipping stores will accept bagged peanuts if you can't reuse them yourself.

**Office practices.** Aside from practicing basic recycling and cutting down on office paper by, for instance, receiving all faxes into our computers rather than fax printers, our major environmental push has involved our catalogs. We emphasize the use of our online catalogs and individual pages, and when printed catalogs are requested, we print them entirely in-house. This enables us to print on demand which means that (A) we can minimize back stock and waste and (B) we can change or add to the catalogs at will without worrying about stock of outdated catalogs. We also have greater control over the paper utilized (all recycled, of course) and the printing process. We use a solid ink color printer which gives us laser quality utilizing waxlike sticks of color inks. These are non-toxic and require minimal packaging, unlike inkjet and laser cartridges.

We utilize non-toxic cleansers and collect compostable food scraps which are taken to local community gardens. (We don't have space to do our own composting unfortunately.) Our energy is purchased through ConEd Solutions, which provides a mix of 100% hydro and wind power.

*Fire & Water founder and owner David Bergman teaches, writes and lectures on eco-design.*

David Bergman Architect

V: 212 475 3106  
F: 212 677 7291  
241 Eldridge Street 3R  
New York, New York 10002

info@cyberg.com  
www.cyberg.com

The FIRE & WATER® collection of contemporary decorative environmentally-conscious lighting, designed by David Bergman, combines innovative uses of recycled and sustainable materials and safe finishes in fixtures designed especially for energy efficient light sources. Our resources include custom recycled glass, biocomposites, recycled plastic and resin, non-toxic finishes, along with cutting edge technologies in lighting.

Fire & Water's award-winning designs are characterized by the compositional use of contrasts: fluid and solid, organic and geometric, grace and strength, "fire & water." We make eco-lighting stylish and appealing – environmentally friendly without compromising design.

**ECO LINES:**

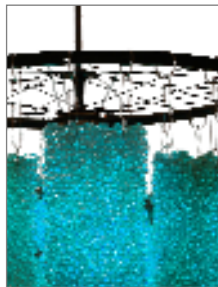

cycLED Series  
 Pages 4



Flipster Series  
 Page 5



Lulu Series  
 Page 7



Fibonacci Series  
 Page 9



Frankie Goes Fluorescent  
 Page 11



Parallel Universe  
 Page 13

**LEGACY LINES and CUSTOM DESIGNS:**



Calla Lily Series  
 Page 15



MR 16 Series  
 Page 17



Custom  
 Page 19

Some Fire & Water products may contribute to LEED® certification credits.  
 Printed on 100% recycled paper with wax ink.



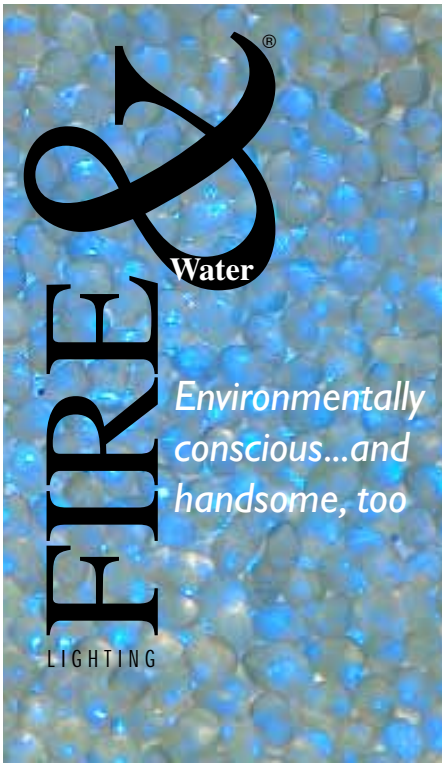

C Y C L E D

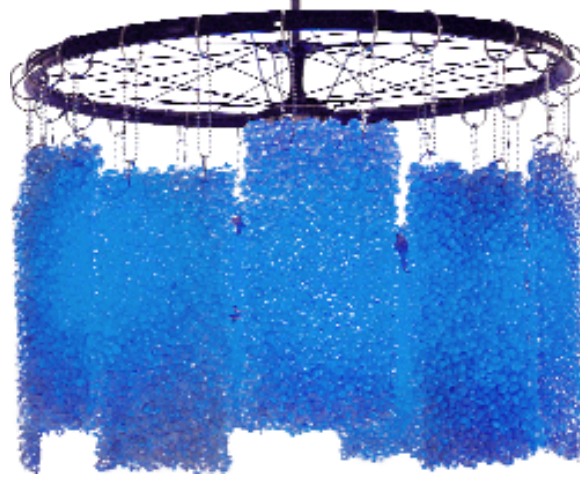

cyclED chandelier  
 Color Changing or White LEDs  
 surrounded by panels of  
 recycled glass pebbles  
 suspended from a  
 salvaged bicycle wheel.  
 Diameter: 25"  
 Height: built to order

Fire & Water Lighting by  
 David Bergman Architect  
 V: 212 475 3106  
 F: 212 677 7291  
 241 Eldridge Street 3R  
 New York, New York 10002

[info@cyberg.com](mailto:info@cyberg.com)  
[www.cyberg.com](http://www.cyberg.com)

**FIRE &**  
Water<sup>®</sup>  
LIGHTING



flipster  
V I V I D

Floor, ceiling, table and  
wall models available;  
Mix and match  
color combinations



David Bergman Architect

V: 212 475 3106

F: 212 677 7291

241 Eldridge Street 3R

New York, New York 10002

[info@cyberg.com](mailto:info@cyberg.com)

[www.cyberg.com](http://www.cyberg.com)



## FLIPSTER SERIES

Flipster Series shades contain over 40% post-industrial recycled PETG, and are recyclable. The resin contains no VOCs, solvents or other potentially harmful emissions.

Lamping is 26 watt 4-pin compact fluorescent bulb(s) with GU24 sockets.

All designs ©David Bergman

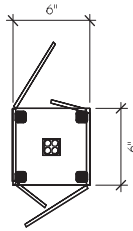
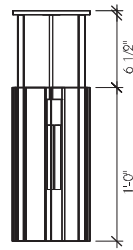

**Ceiling Fixture**  
F&W #101

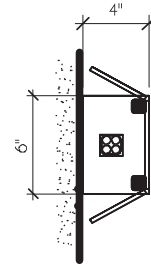
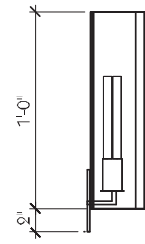

**Sconce**  
F&W #102

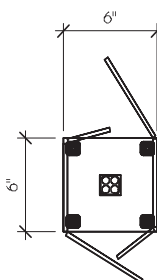
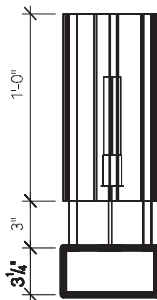

**Table Lamp**  
F&W #103

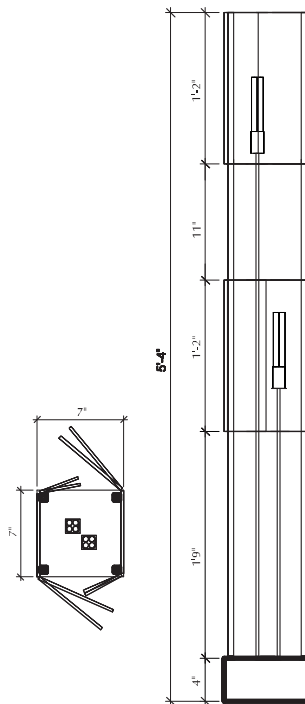

**Floor Lamp**  
F&W #104

David Bergman Architect

V: 212 475 3106  
F: 212 677 7291  
241 Eldridge Street 3R  
New York, New York 10002

info@cyberg.com  
www.cyberg.com



## LULU SERIES

*Environmentally conscious...  
and handsome, too*



David Bergman Architect

V: 212 475 3106  
F: 212 677 7291  
241 Eldridge Street 3R  
New York, New York 10002

[info@cyberg.com](mailto:info@cyberg.com)  
[www.cyberg.com](http://www.cyberg.com)

i d r a   
2001 Award Winner

## LULU SERIES

Lulu Series fixtures are lamped with 26 watt 4-pin compact fluorescent bulb(s) with GU24 sockets. All models except for F&W # 73 use two bulbs.

Shades are made of recycled plastic (50% recycled content).

Bases are made of an environmental bio-composite resembling granite.

All designs ©David Bergman

David Bergman Architect

V: 212 475 3106  
 F: 212 677 7291  
 241 Eldridge Street 3R  
 New York, New York 10002

info@cyberg.com  
 www.cyberg.com

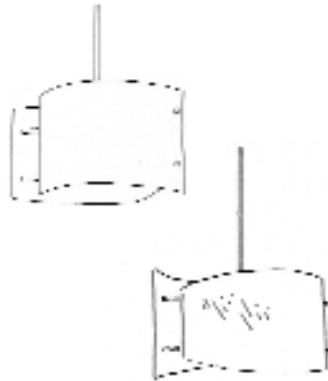

### Pendants

F&W #71 (straight) & #72 (tapered)  
 17" W x 10.5" D x 9" H (shade only)

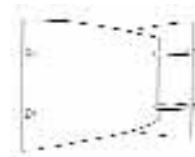

### Sconce

F&W #73  
 15" W x 4" D x 10" H  
 ADA Compliant

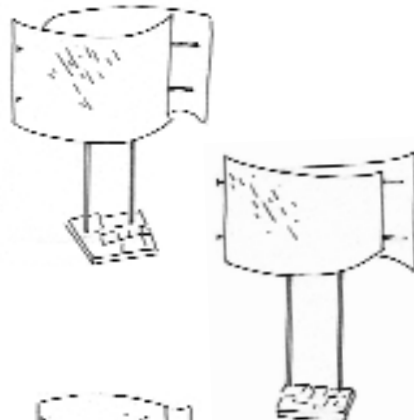

### Table Lamps

F&W #74 (straight) & #75 (tapered)  
 17" W x 10.5" D x 22.5" H



### Floor Lamp

F&W #76  
 17" W x 10.5" D x 63.5" H

Fibonacci  
Series



*Environmentally conscious...  
and handsome, too*



David Bergman Architect

V: 212 475 3106  
F: 212 677 7291  
241 Eldridge Street 3R  
New York, New York 10002

[info@cyberg.com](mailto:info@cyberg.com)  
[www.cyberg.com](http://www.cyberg.com)

94

FIBONACCI SERIES

Fibonacci Series shades are made of post-industrial recycled or sustainably harvested wood veneer with a paper backer.

Lamping is 26 watt 4-pin compact fluorescent bulb with GU24 sockets.

All designs ©David Bergman

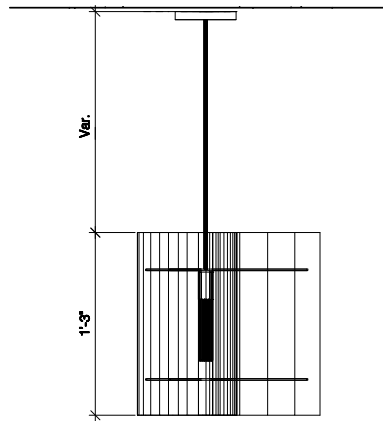

Ceiling Fixture  
F&W #91

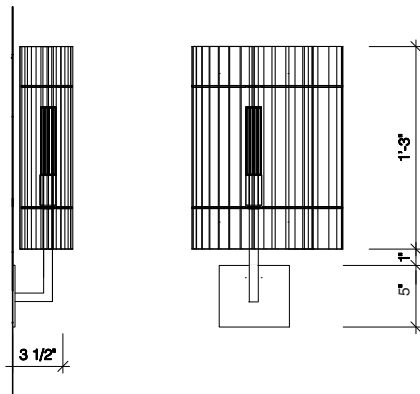

Sconce  
F&W #93

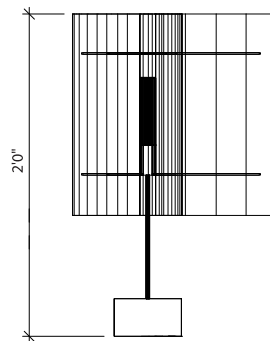
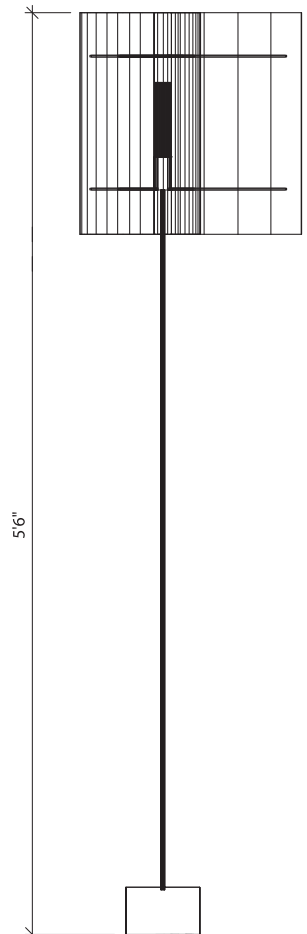

Table Lamp  
F&W #94



Floor Lamp  
F&W #95

David Bergman Architect

V: 212 475 3106  
F: 212 677 7291  
241 Eldridge Street 3R  
New York, New York 10002

info@cyberg.com  
www.cyberg.com



62



61

FRANKIE  
 GOES  
 FLUORESCENT

Environmentally conscious...  
 and handsome, too



63 (Shown with non-recycled art glass)



64



1998 Award Winner

David Bergman Architect

V: 212 475 3106  
 F: 212 677 7291  
 241 Eldridge Street 3R  
 New York, New York 10002

[info@cyberg.com](mailto:info@cyberg.com)  
[www.cyberg.com](http://www.cyberg.com)

# FRANKIE GOES FLUORESCENT

Frankie Goes Fluorescent fixtures are lamped with 26 watt 4-pin compact fluorescent bulb with GU24 sockets.

Recycled glass shades are available in white, pale green or cobalt blue.

Solid portions of fixtures are made of an environmental bio-composite resembling granite.

All designs ©David Bergman

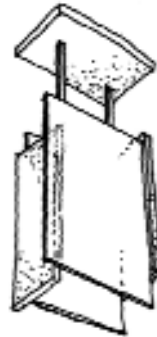

## Ceiling Fixture

F&W #61  
 5" D x 8" W x 20" H

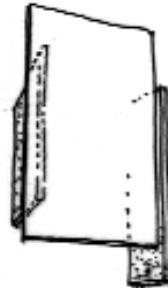

## Sconce - Vertical

F&W #62  
 4" D x 7 1/2" W x 13 1/2" H  
 ADA Compliant



## Sconce - Horizontal

F&W #63  
 4" D x 12" W x 9" H  
 ADA Compliant

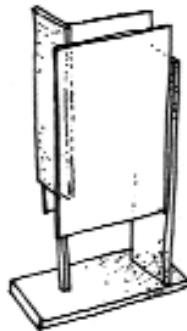

## Table Lamp

F&W #64  
 5" D x 10" W x 18" H

David Bergman Architect

V: 212 475 3106  
 F: 212 677 7291  
 241 Eldridge Street 3R  
 New York, New York 10002

info@cyberg.com  
 www.cyberg.com



*Looking at the universe through multi-colored glass*



81



83

P  
A  
R  
A  
L  
L  
E  
L  
  
 U  
N  
I  
V  
E  
R  
S  
E

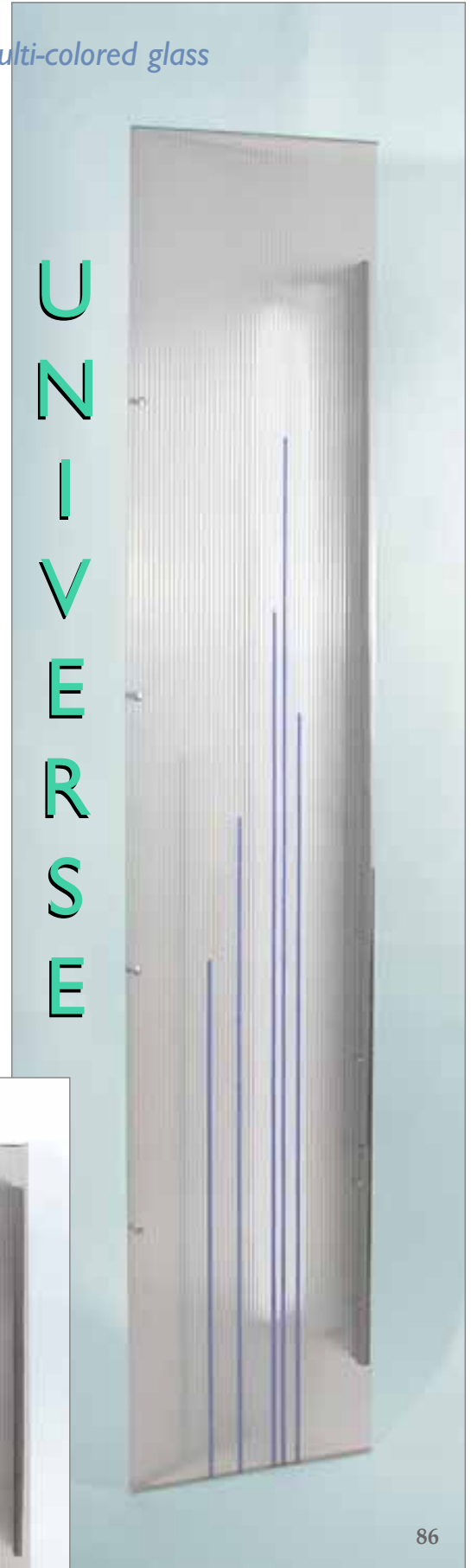

86

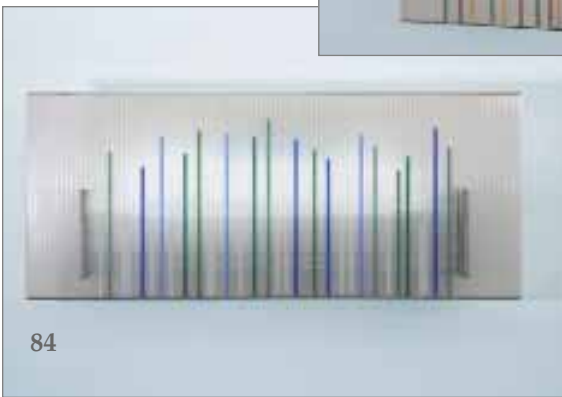

84



85

*Environmentally conscious...  
 and handsome, too*

David Bergman Architect

V: 212 475 3106  
 F: 212 677 7291  
 241 Eldridge Street 3R  
 New York, New York 10002

[info@cyberg.com](mailto:info@cyberg.com)  
[www.cyberg.com](http://www.cyberg.com)

Parallel Universe fixtures are made of polycarbonate, stripes of recycled glass, wood pulp corrugated board, and aluminum.

Colors and layout of stripes are customized for each order.

Parallel Universe fixtures are available with dimming or non-dimming ballasts. Lamping is 36 watt T5 on all models except floor lamp, which has a 32 watt T8.

Fluorescent dimmers are included with table and floor lamps.

Lutron fluorescent dimmers must be separately purchased for ceiling and Sconces. See Lutron specifications for wiring.

All designs ©David Bergman

David Bergman Architect

V: 212 475 3106  
 F: 212 677 7291  
 241 Eldridge Street 3R  
 New York, New York 10002

info@cyberg.com  
 www.cyberg.com

PARALLEL UNIVERSE

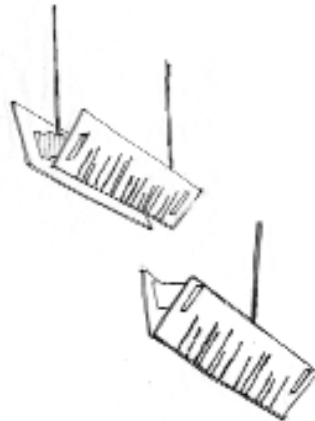

Ceiling Fixture (Uplight)

F&W #81  
 24" W x 11" D x 10" H (diffuser only)

Ceiling Fixture (Downlight)

F&W #82  
 Available Soon



Wall Sconce

F&W #83  
 11" W x 24" H x 4" D  
 ADA Compliant

Wall Sconce

F&W #84  
 24" W x 10" H x 4" D  
 ADA Compliant



Table Lamp

F&W #85  
 10" W x 24" H x 6 1/2" D

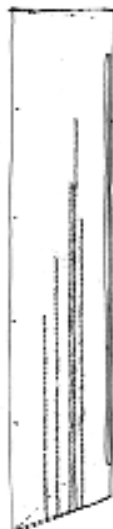

Floor Lamp

F&W #86  
 11" W x 60" H x 7" D



## CALLA LILY SERIES

*Variations, custom designs and special finishes are available.*



David Bergman Architect

V: 212 475 3106  
F: 212 677 7291  
241 Eldridge Street 3R  
New York, New York 10002

[info@cyberg.com](mailto:info@cyberg.com)  
[www.cyberg.com](http://www.cyberg.com)

**CALLA LILY SERIES**

Calla Lily fixtures have candelabra sockets for incandescent or krypton/xenon (60w max.) lamps. Calla Lily sconces may be ordered hard-wired or with cordset.

The mesh is raw copper and subject to oxidizing and staining. It is an industrial material and may have inconsistencies in the weave.

Sconces #21 and 26 are available in mirror image pairs.

Copper may be ordered clear lacquered, natural or patinated (extra). Table and floor lamp bases are made of an environmental composite which looks like granite.

All designs ©David Bergman

David Bergman Architect

V: 212 475 3106  
F: 212 677 7291  
241 Eldridge Street 3R  
New York, New York 10002

info@cyberg.com  
www.cyberg.com



**Sconce**  
F&W #21  
26" H x 8" W x 4" - 5" D  
ADA Compliant



**Sconce**  
F&W #26  
ADA Compliant  
28" H x 14" W x 4" - 5" D



**Floor Lamp**  
F&W #23  
79" H x 22" x 14"



**Ceiling Fixture**  
F&W #25  
26" D x 36" H



**Table Lamp**  
F&W #24  
28" H x 14" x 8"



**Sconce**  
F&W #27  
Approx. 15" H x 20" W x 10" D

*Double mesh (brass and copper) diffusers optional.*



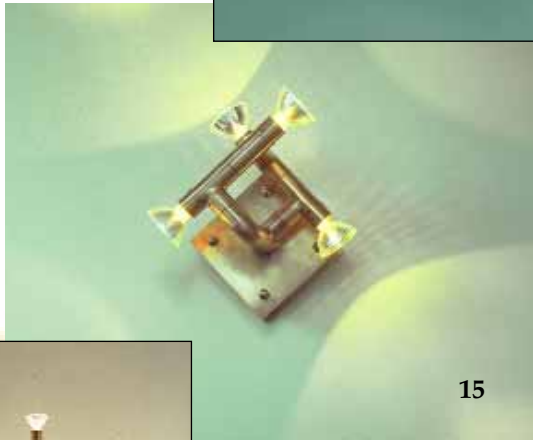
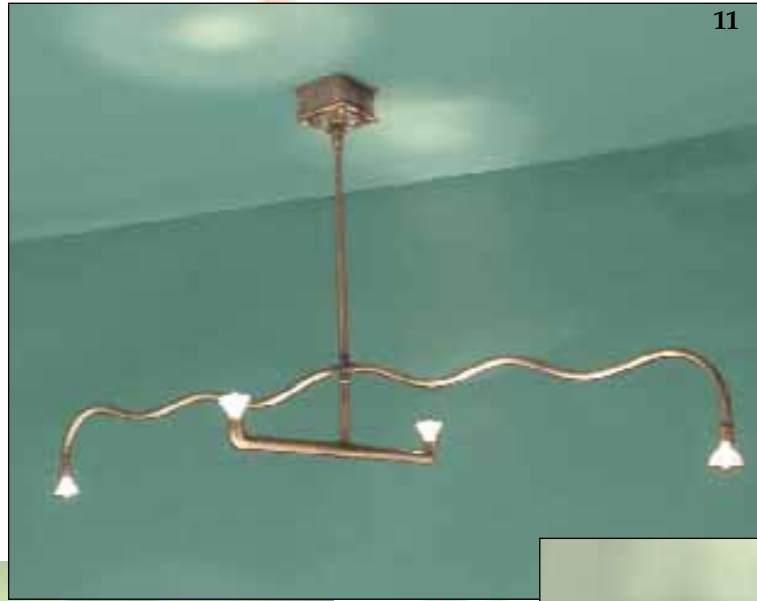

## MR16 SERIES



*Variations, custom designs and special finishes are available.*

**David Bergman Architect**

V: 212 475 3106

F: 212 677 7291

241 Eldridge Street 3R

New York, New York 10002

[info@cyberg.com](mailto:info@cyberg.com)

[www.cyberg.com](http://www.cyberg.com)



MR16 fixtures are wired for 20 or 35 watt lamps. Regular dimmers maybe used, however electronic low-voltage dimmers are recommended to eliminate noise. Fixtures are also available for remote transformer installation.

Copper may be ordered clear lacquered, natural or patinated (extra). Floor lamp bases are made of an environmental composite resembling granite.

All designs ©David Bergman

David Bergman Architect

V: 212 475 3106  
 F: 212 677 7291  
 241 Eldridge Street 3R  
 New York, New York 10002

info@cyberg.com  
 www.cyberg.com

## MR16 SERIES

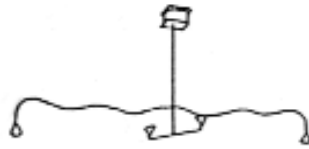

### Ceiling Fixture

F&W #11

56" x 24" x Height (to be specified)

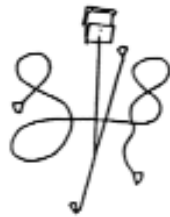

### Ceiling Fixture

F&W #12

38" x 46" x Height (to be specified)



### Ceiling Fixture

F&W #14

10" x 10" x Height (to be specified)



### Sconce

F&W #15

8 1/2" W x 9" H x 7" D

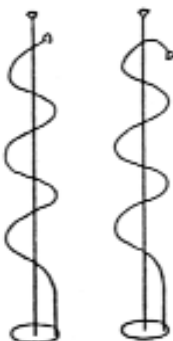

### Floor Lamps

F&W #16

F&W #17

67" H x 14" Diameter



Wilmington Trust, New York  
Montroy Andersen, Architects



Treetops Restaurant  
Rittenhouse Square  
Philadelphia, PA

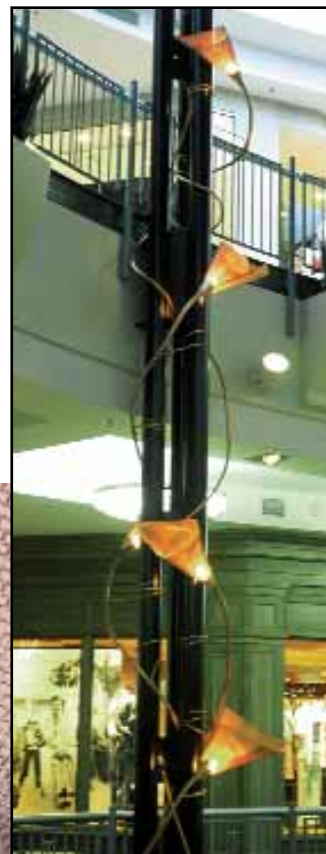

Circle Center, Indianapolis  
Ehrenkratz & Eckstut, Architects

# CUSTOM DESIGNS AND INSTALLATIONS



Wedding Installation



Menorah for The San Francisco Jewish Museum

David Bergman Architect

V: 212 475 3106

F: 212 677 7291

241 Eldridge Street 3R

New York, New York 10002

[info@cyberg.com](mailto:info@cyberg.com)

[www.cyberg.com](http://www.cyberg.com)

## GENERAL INFORMATION

- Custom finishes and variations are available at additional cost (subject to availability).
- Crating, shipping, transit insurance, tax and installation costs are not included in price.
- All standard orders require fifty percent (50%) deposit and written description of products desired prior to production. Custom orders require seventy percent (70%) deposit and description. Balance remaining **MUST** be paid upon completion of order and prior to shipping. Orders will be processed as indicated on Fire & Water® invoice which is the final agreement between Fire & Water (F&W) and purchasing organization. Any discrepancies between the purchasing organization and F&W must be submitted to F&W attention, in writing, within 14 days from date of confirmation.
- F&W acceptance of an order is final and binding. F&W reserves the right to allow cancellation of an order after confirmation and prior to shipping, but may retain the purchasing agency's deposit as a condition of cancellation. Delivered orders may not be returned for any reason except when repairs or replacement is indicated.
- F&W products are warranted against defective craftsmanship and materials for up to one (1) year from delivery date. F&W will, at its discretion, repair or replace defective product free of charge. This warranty does not extend to damage resulting from shipping, accident, misuse, tampering, alterations, neglect or abuse, nor does it apply to unauthorized repairs. Manufacturing imperfections in metal mesh and in certain other materials are inherent in the materials and are not to be considered a defect in the materials or manufacturing process used and are **NOT** covered under warranty. In no way shall F&W liability exceed the original purchase price of the product.
- No returns will be accepted without prior authorization.
- Standard delivery is 8 - 12 weeks from receipt of deposit (subject to availability and other "acts of God"). F&W will choose appropriate freight carrier unless specifically directed in writing. Purchasing agency is required to assume responsibility for local delivery, installation and size constraints of doorways, elevators, etc.
- All product is shipped at the purchasing agency's own risk after it has been fully and completely inspected and packed by F&W. It is accepted as such by the carrier. Prior to accepting F&W products from the carrier, fully inspect and note any damage or loss on the delivery receipt. If damage is noted after carrier has departed, immediately contact freight carrier and arrange for an inspection. Claims against F&W will only be considered if made in writing and received within ten (10) days from receipt. Failure to make such claim shall constitute acceptance of the merchandise and waiver of any defects, errors or shortage. F&W will not be liable for consequential damages.
- All accounts which are not paid in full when due shall bear a finance charge of one and one-half percent (1.5%) per month from date accrued.

Fire & Water reserves the right to change published prices at any time, but will make every effort to notify buyers 30 days prior.